

Round Bottom Roll Off



Standard Features:

- 12 Ga Camlock or T-Lock Doors
- 12 Ga Front & Sides
- 10 Ga Floor
- 3" Channel Cross Members- 16" Centers
- 8" x 8" Bogey Wheels Front & Rear
- Main Rails 6" Channel or 5" I-Beam
- 3" x 3" Tubing Floor Sill
- 3" x 3" Tubing Header
- Mitered Corners to Protect Tarps
- Manufactured using Prime Steel
- Rust Inhibitive Primer (Inside & Out) and Underseal (Bottom)
- Industrial Enamel Finish Coat

Heavy Duty:

- 10 Gauge Front & Sides
- 7 Gauge Floor
- 3" Channel Cross Members- 16" Centers

Additional Options Upon Request:

- One Piece or Water Tight Door
- Rolling, Flip, or Recycling Roof
- Custom Wheels or Stands
- All Types of Hook-Ups Available
- Tarp Rails, Push Plates, Lift Eyes, & Dividers
- Custom Paint and Primer
- ID Weld or Stencil



McLaughlin Waste Equipment, INC.
11900 E. Locke Rd. Lockeford, Ca 95237
Office: (209) 367-8810 Fax: (209) 367-8629

www.mwecans.com

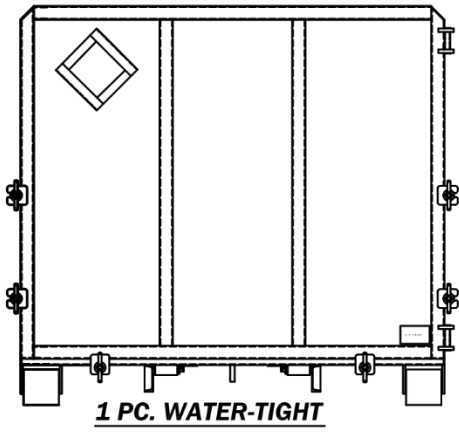
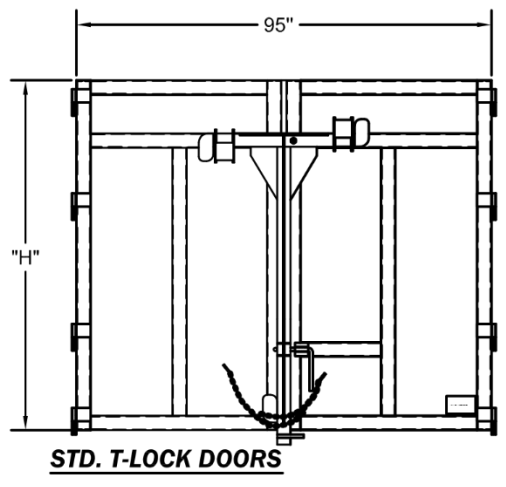
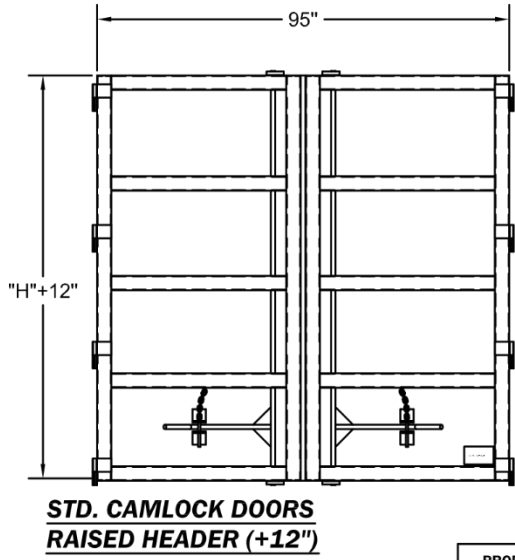
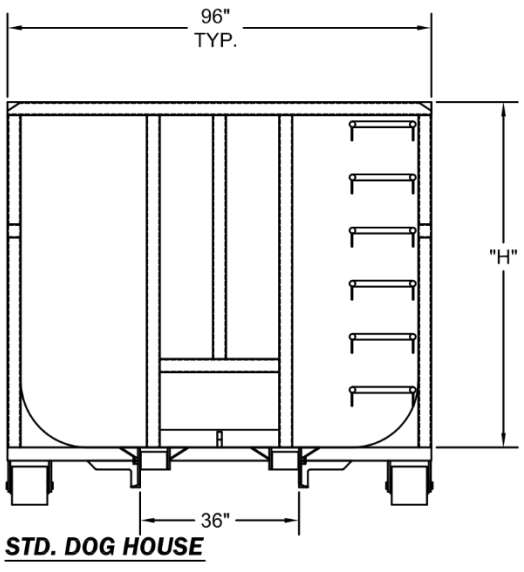
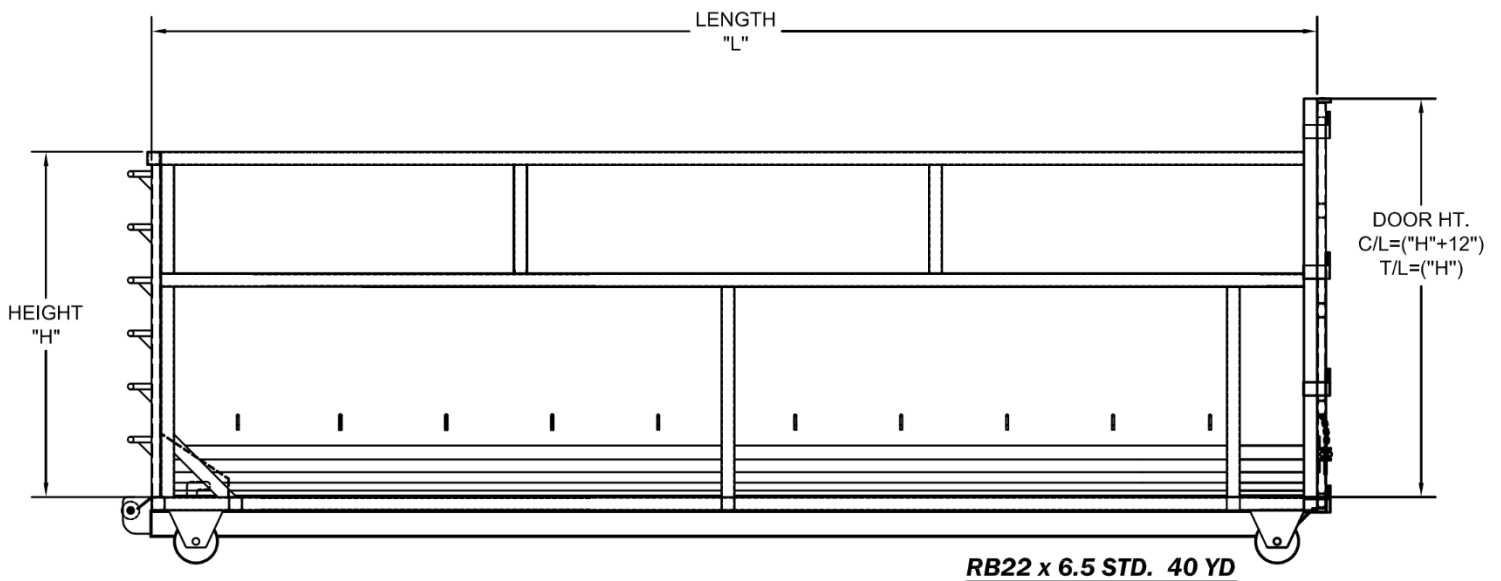

| PRODUCT # | VOLUME YDS | LENGTH "L" (FT) | HEIGHT "H" (IN) | WEIGHT APPROX. |
|-------------|------------|-----------------|-----------------|----------------|
| RORB14 X 32 | 10 | 14 | 32" | |
| RORB18 X 36 | 15 | 18 | 36" | |
| RORB14 X 64 | 20 | 14 | 64" | |
| RORB16 X 54 | 20 | 16 | 54" | |
| RORB18 X 72 | 30 | 18 | 72" | |
| RORB18 X 96 | 40 | 18 | 96" | |
| RORB22 X 78 | 40 | 22 | 78" | |
| RORB22 X 99 | 50 | 22 | 99" | |
| | | | | |
| | | | | |
| | | | | |



Proud member of The California Refuse Removal Council (CRRC), Solid Waste Association of America (SWANA), and The Clara Mateo Garbage Association.

These containers meet or exceed ANSI Z245.3 container safety requirements, and carry a 2 Yr. Warranty.

Note: All specifications are subject to change without notice. Unless stated otherwise in writing, container sizes indicated are nominal sizes. Actual volume may vary from nominal sizes.